

Electro Mechanical Specifications

Nominal Chassis Diameter	15 inch/381 mm
Impedance	8 Ω ¹
Power Handling	600 (A.E.S.) ²
Maximum Output Continuous/Peak	122/128 dB
Power Compression at Rated Power	4.8 dB
Usable Frequency Range (-6 dB)	40 Hz-3 kHz
Average Sensitivity (in above range) 1 W/1 m	99 dB
Resonance	42 Hz
Moving Mass inc. Air Load	103 grams
BL Product (Newtons/amp)	23.6
Minimum Impedance (Zmin)	7.5 Ω
Effective Piston Diameter	13.03 inch/331 mm
Flux Density	1.04 Tesla
Magnetic Gap Depth	0.43 inch/11 mm
Coil Winding Height	0.75 inch/19 mm
Voice Coil Length	95 feet/29 m
Magnet Weight	120 oz/3.4 kg
Maximum Cone Displacement	0.55 inch/14 mm
Peak Displacement Volume of Cone, Vd	0.98 litres
Voice Coil Diameter	4.0 inch/102 mm

Thiele & Small Parameters

Resonant Frequency fs	42 Hz
D.C Resistance Re	6 Ω
Qts	0.278
Qes	0.295
Qms	4.82
Mms (grams)	103
Cms (microns per Newton)	139
BL Product	23.6 Tesla metres
Vas	139 litres
Reference Efficiency no	3.51 %
Piston Area Sd	0.086 m ²
Xmax	5.7 mm

Mounting Information

Overall Diameter	16"/406.4 mm
Width Across Flats	15.25"/387 mm
Flange Thickness	0.305"/7.8 mm
Baffle Hole Diameter, Front Mount	13.85"/352 mm
Baffle Hole Diameter, Rear Mount	14"/355.6 mm
Gasket Supplied	Front & Rear
Fixing Holes	4 x 0.281" diam on 15.5 PCD/8 x 0.281 diam on 14.56 PCD 4 x 7.1 mm diam on 393.7 PCD/8 x 7.1 diam on 370 PCD
Depth	7.20"/183 mm
Weight	27.28 lb/12.4 kg
Recommended Enclosure Volume	2.47-4.41 cu ft/70-125 litres
Volume Displaced by Driver	0.219 cu ft/6.2 litres
Shipping Weight	30.58 lb/13.9 kg
Packing Carton Dimensions	415 x 415 x 250 mm

Colossus 15B-600

The Colossus 15B-600 is intended for use in high-power two-way ported enclosures and as a high-output bass driver in multiway systems. It features a 4-inch voice coil immersed in a symmetric magnetic field yielding increased linearity and lower distortion at high excursion levels. The cone membrane, manufactured from Polycellulose, is much stronger and more durable than conventional paper pulp alternatives. This allows the driver to combine high-sensitivity with the structural integrity required to produce undistorted low frequencies at high output levels. The driver handles 600 Watts (A.E.S) continuous and can cope with peaks in excess of 2400 Watts. This is due to advanced thermal management in the form of vented die-cast chassis and motor system coupled to a large vaned heatsink mounted on the rear of the unit. These measures effectively remove heat from the voice coil, resulting in extremely low-power compression. The Colossus 15B-600 exhibits an average sensitivity of 99 dB and can deliver bass down to 40 Hz (-6 dB) in a 125 litre ported enclosure.



FANE INTERNATIONAL LTD.
Sovereign House
Gilcar Way
Wakefield Europort
Castleford WF10 5QS
England
TEL +44 (0) 1924 224618
FAX +44 (0) 1924 899166
info@fane-international.com
www.fane-international.com



Frequency Response Data

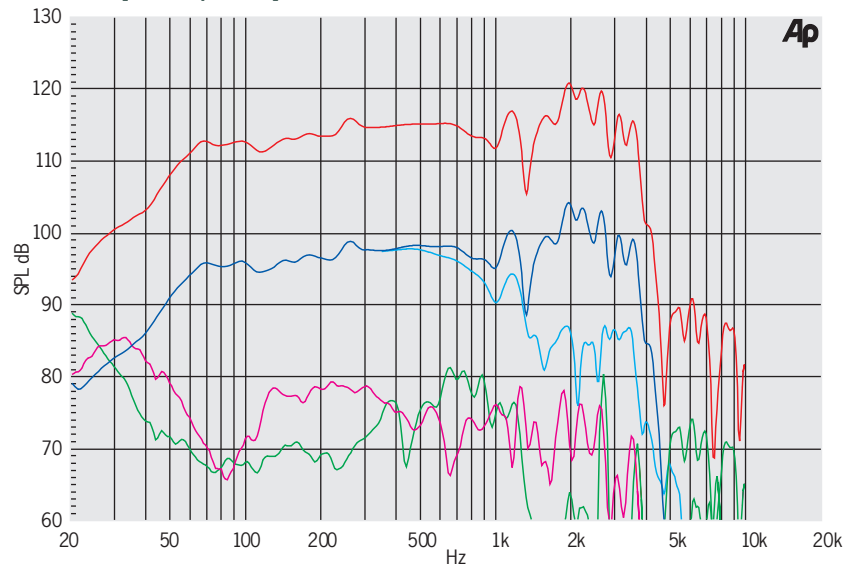

Data measured using swept sine wave input on an open baffle of dimensions 2.5 x 3.7 metres with a microphone distance of 1 metre.

— Fundamental 10 % Power
— Fundamental on-axis 1 W
— Fundamental 45° off-axis 1 W
— 2nd Harmonic 10 % Power
— 3rd Harmonic 10 % Power

1 Please inquire about alternative impedances.

2 A.E.S. power handling test. Pink noise bandpass filtered at 12 db per octave with cutoff frequencies of 30 Hz and 300 Hz. Driver mounted in free air, test signal applied at rated power for two hours.

Materials of Construction

Coil Former	Fibreglass
Voice Coil	Aluminium
Magnet Material	Ferrite
Chassis	Die-cast Aluminium
Cone	Curvilinear Polycellulose
Surround/Edge Termination	Polyvinyl Damped Dbl. Half Roll Linen
Dust Dome	Solid Paper
Connectors	Push-button Spring Terminals
Polarity	Positive Voltage at Red Terminal Causes Forward Motion of Cone

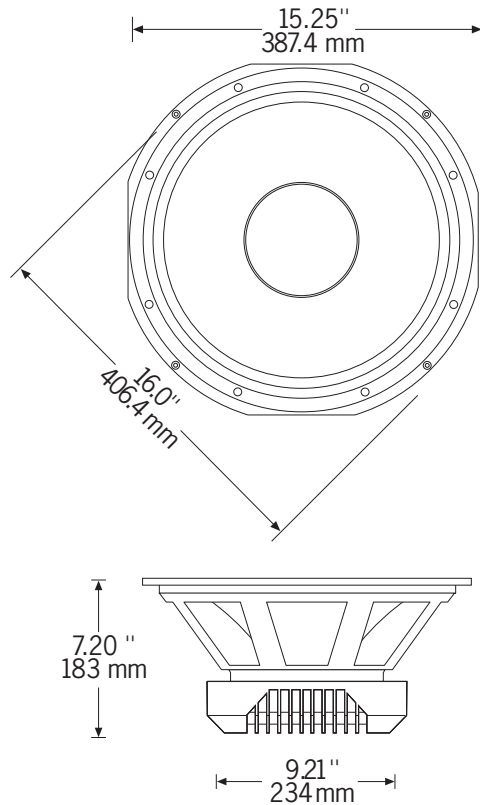

Impedance

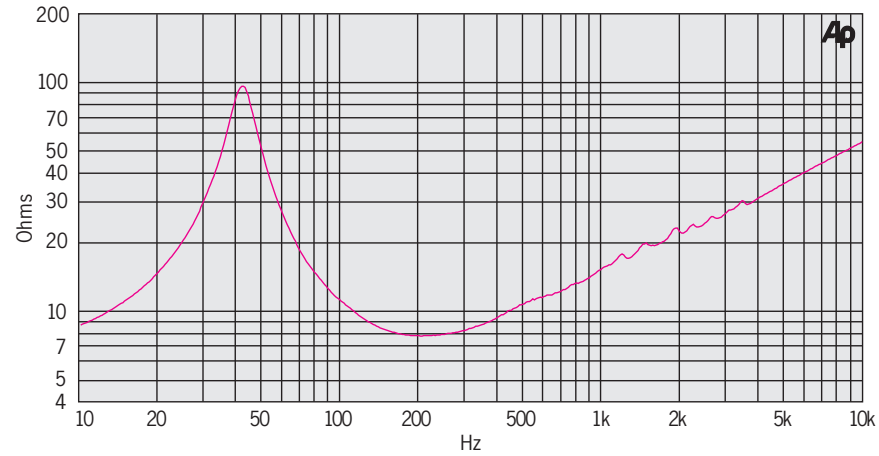

Computer Predicted Bass Response

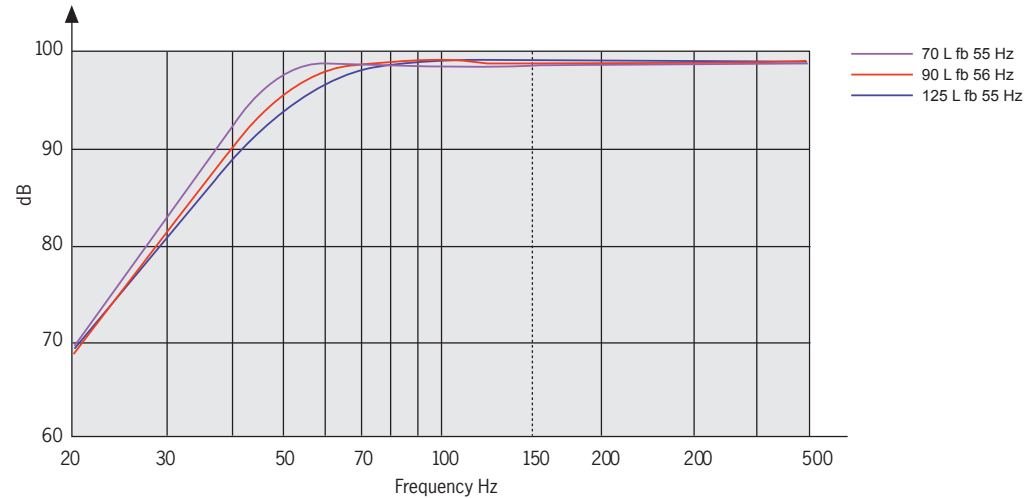

Colossus 15B-600

Fane International Ltd. operates a policy of continuous product development and reserves the right to change specifications without notice.

FANE INTERNATIONAL LTD.
Sovereign House Gilcar Way, Wakefield Europort Castleford WF10 5QS, England
TEL +44 (0) 1924 224618 FAX +44 (0) 1924 899166 info@fane-international.com www.fane-international.com

