

# *Millenium*

HD-100  
e-drum set



Musikhaus Thomann e.K.  
Treppendorf 30  
96138 Burgebrach  
Germany  
Telephone: +49 (0) 9546 9223-0  
email: [info@thomann.de](mailto:info@thomann.de)  
Internet: [www.thomann.de](http://www.thomann.de)

23.12.2011

---

## Table of contents

1	General notes.....	4
2	Safety instructions.....	5
3	Features.....	6
4	Operating elements.....	7
5	Setting up the drum set.....	10
6	MIDI-out format.....	14
7	Functions.....	16
8	Recording.....	23
9	Playback.....	26
10	Technical specifications.....	30
11	Voice list.....	31
12	Pattern list.....	34
13	Percussion settings.....	35
14	MIDI implementation chart.....	38
15	Cleaning.....	40
16	Protecting the environment.....	41

## 1 General notes

This user manual contains important information on the safe operation of the device. Read and follow all safety notes and all instructions. Save this manual for future reference. Make sure that it is available to all persons using this device. If you sell the device to another user, be sure that they also receive this manual.

Our products are subject to a process of continuous development. We therefore reserve the right to make changes without notice.

### Symbols and signal words

This section gives an overview of the symbols and signal words used in this user manual.

Signal word	Meaning
<b>DANGER!</b>	This combination of symbol and signal word indicates an immediate dangerous situation that will result in death or serious injury if it is not avoided.
<b>CAUTION!</b>	This combination of symbol and signal word indicates a possible dangerous situation that can result in minor injury if it is not avoided.
<b>NOTICE!</b>	This combination of symbol and signal word indicates a possible dangerous situation that can result in material and environmental damage if it is not avoided.
Warning signs	Type of danger
	Warning – danger zone.

## 2 Safety instructions

### Intended use

Use the device only as described in this user manual. Any other use or use under other operating conditions is considered to be improper and may result in personal injury or property damage. No liability will be assumed for damages resulting from improper use.

This device may be used only by persons with sufficient physical, sensorial, and intellectual abilities and having corresponding knowledge and experience. Other persons may use this device only if they are supervised or instructed by a person who is responsible for their safety.

### Safety

#### **DANGER!**

##### **Danger for children**

Ensure that plastic bags, packaging, etc. are disposed of properly and are not within reach of babies and young children. Choking hazard!

Ensure that children do not detach any small parts (e.g. knobs or the like) from the unit. They could swallow the pieces and choke!

Never let children unattended use electrical devices.

#### **CAUTION!**

##### **Possible hearing damage**

With loudspeakers or headphones connected, the device can produce volume levels that may cause temporary or permanent hearing impairment.

Do not operate the device permanently at a high volume level. Decrease the volume level immediately if you experience ringing in your ears or hearing impairment.

#### **NOTICE!**

##### **Operating conditions**

This device has been designed for indoor use only. To prevent damage, never expose the device to any liquid or moisture. Avoid direct sunlight, heavy dirt, and strong vibrations.

#### **NOTICE!**

##### **External power supply**

The device is powered by an external power supply. Before connecting the external power supply, ensure that the input voltage (AC outlet) matches the voltage rating of the device and that the AC outlet is protected by a residual current circuit breaker. Failure to do so could result in damage to the device and possibly the user.

Unplug the external power supply before electrical storms occur and when the device is unused for long periods of time to reduce the risk of electric shock or fire.

### 3 Features

- 100 drum and percussion sounds with high-grade resolution
- 10 preset kits and 5 programmable kits
- 40 built-in preset rhythms, one user pattern
- Integrated metronome with 4 selectable click sounds
- Bass pad
- Including foot pedal, double zone snare pad, 3x tom pads, ride pad, crash pad, hi-hat pads & hi-hat controller
- Headphones output & mix input
- USB connection

## 4 Operating elements

### Top panel

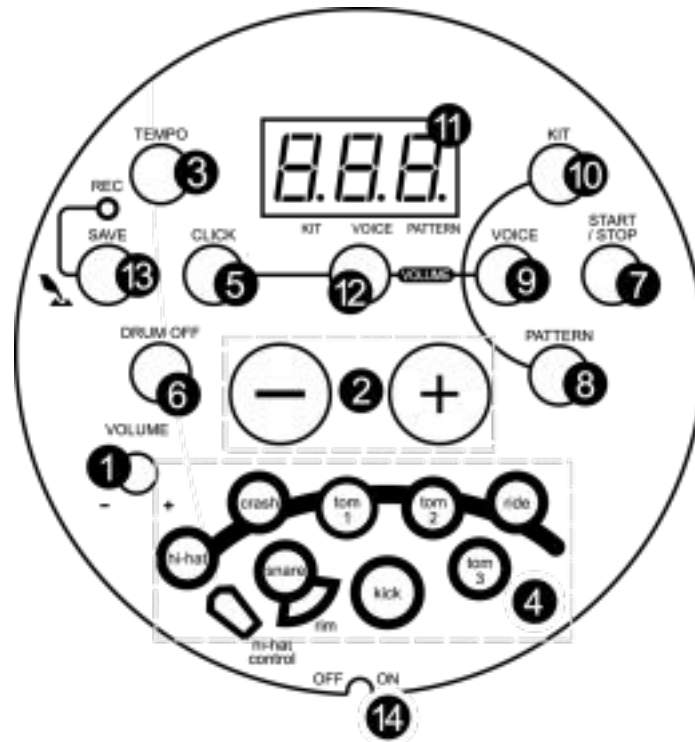

- |   |                  |  |
|---|------------------|--|
| 1 | [VOLUME]         | Volume control for the headphones output. Turn it clockwise to increase the volume, turn it counterclockwise to decrease the volume. |
| 2 | [+/-]            | Use these buttons to increase or decrease the value of the currently selected parameter.   |
| 3 | [TEMPO]          | For tempo adjustment.  |
| 4 | 'Pad indicators' | During playing these indicators show the currently triggered pads.   |
| 5 | [CLICK]          | Button for switching the metronome function on / off.  |
| 6 | [DRUM OFF]       | Use this button to mute the drum part of a song.   |
| 7 | [START/STOP]     | Button to start / stop song playback.  |

8	<i>[PATTERN]</i> For selecting the patterns and for choosing the MIDI output format.
9	<i>[VOICE]</i> Use this button to select the desired voice.
10	<i>[KIT]</i> Button for selecting a drum kit.
11	LED display Shows the parameters of the currently selected menu.
12	<i>[VOLUME]</i> To separately adjust the volume of the drum kit, the voice, the metronome and the pattern.
13	<i>[SAVE/REC]</i> Press this button briefly to store the currently selected kit as user kit. Keep this button pressed, to start the record mode.
14	<i>[ON/OFF]</i> Use this button to turn the unit on and off.

**Rear panel**

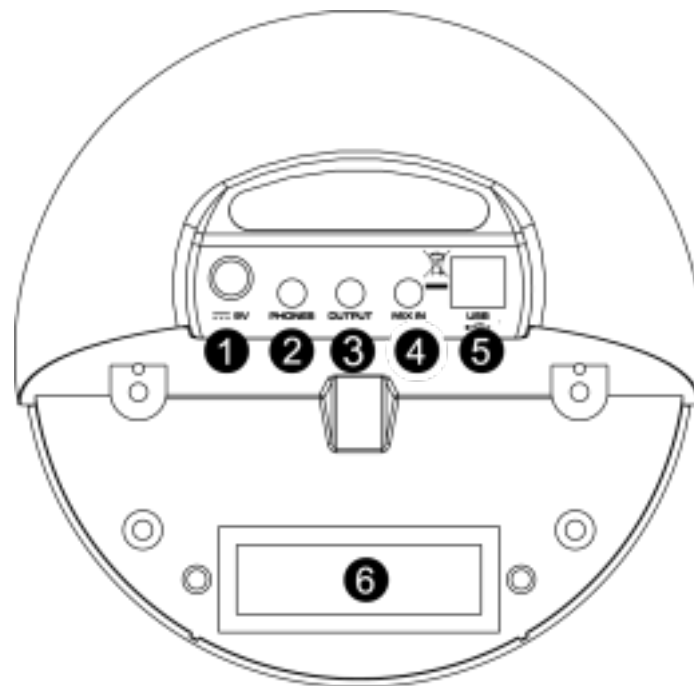

1	DC 9 V Plug in the cable of the mains adaptor here.
2	PHONES Here you can connect your headphones (not supplied).
3	OUTPUT You can connect an audio system or drum monitor to this stereo output.
4	MIX IN Connect external audio devices like MP3 or CD players to this input.
5	USB Use this socket to connect the unit to a computer (MIDI in/out via USB).
6	Trigger inputs Connect the individual pads to these sockets

### 5 Setting up the drum set

Unpack and check carefully there is no transportation damage before using the unit.

Establish all connections as long as the unit is switched off. Use the shortest possible high-quality cables for all connections.

#### Connecting pads and pedals

Connect each of the trigger inputs on the rear panel of the drum module using the supplied cables with the corresponding pad. The snare drum is equipped with a stereo input, and thus supports double-triggering. Also for the hi-hat pedal a stereo input is available.

Notes:

- The sound of hitting the hi-hat pad is controlled by the hi-hat pedal. Similar to a real drum kit, the hi-hat sounds 'open' when the pedal is released. If you step on the pedal the hi-hat sounds 'closed'.
- The half of the pad on the players side is the effective striking area of a cymbal pad (ride, crash or hi-hat). In this respect cymbal pads differ from other pads.



HD-100

**th.mann**  
MUSIC IS OUR PASSION

### Connecting the power supply

Make sure the device is switched OFF, then insert the power supply into a wall outlet and connect the adaptor cable to the DC IN socket on the rear panel of the device.

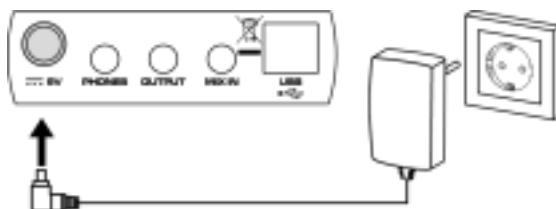

To protect the speakers, amplifier and the drum module from damage rotate the volume knob to the left stop, **before** switching the power ON.

### Connecting audio equipment

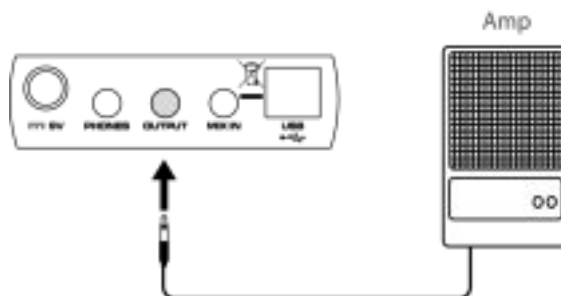

If you want to listen to the drum voices using an amplifier, connect the input of the amp to the OUTPUT jacks on the rear panel.

### Connecting a CD player, etc.

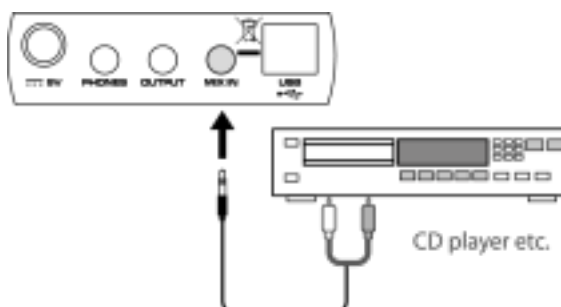

You can connect the audio output of a CD player or other audio source to the MIX IN socket on the rear panel to mix the external signals with the drum sound. This function is convenient if you want to play along with your favourite song.

### Connecting headphones

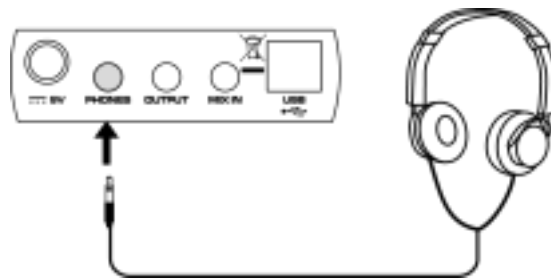

An optional set of stereo headphones (not supplied) can be connected to the PHONES socket located on the rear of the drum module. Listening to music with high sound pressure level may cause permanent damage to your hearing. For your own protection we recommend to adjust the volume to a comfortable level!

### Connecting a MIDI / USB device

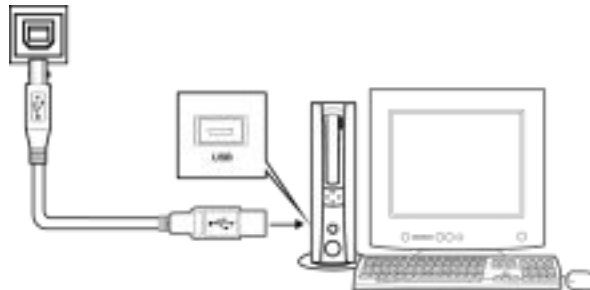

- You can connect a computer or other USB host devices that supports USB audio.
- When using devices with a USB cable, you can choose 'USB Audio Device' from the device menu of the software to transfer the MIDI data. The USB connection is compatible with current operating systems. A driver is not needed.
- The drum module sends all midi data that is generated while you're playing through the USB port, except click and midi codes of the songs. The USB port only sends and receives MIDI messages.



*Channel 11 is set as default percussion channel.*

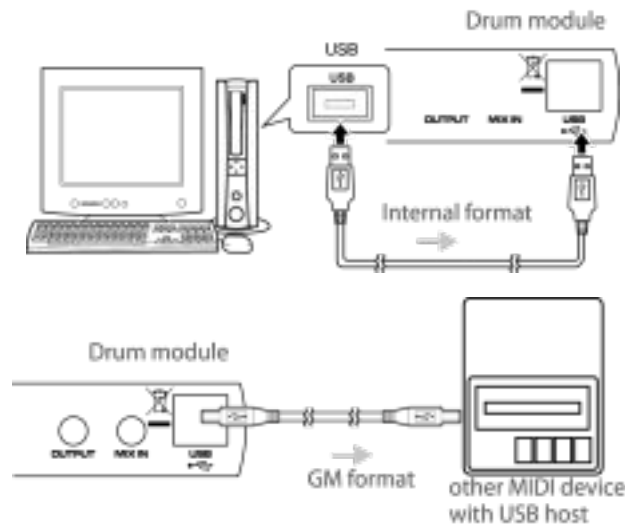

## 6 MIDI-out format

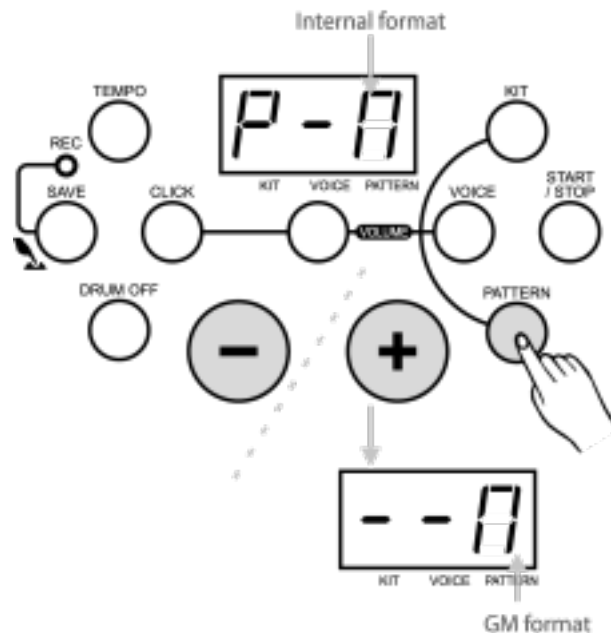

One of the two different MIDI output formats can be selected for the drum module: the **internal** format (default setting) and the **GM** format.

- The internal format is used when the drum module works as a sound source (drum module must be connected to a computer or other module with USB host device by USB, and send midi data to another drum module. One drum module can't be connected to another drum module by USB).
- The GM format is used when some other sound source is applied (drum module to other product which supports GM format), such as a computer. If you record your own drum play to computer software with internal format, then only the drum module could recognize and playback your own song (i.e. the recorded midi file) correctly. Nevertheless, if you would like to playback your recorded midi song by any sound source device which supports GM format, we suggest you to record your own drum performance with GM format output.



1.  In pattern selecting mode, press the [PATTERN] button to enter MIDI output format choice mode.
  - ⇒ The LED display then shows the current MIDI output format 'P-N' (default setting, internal format) or '--N' (GM format).
2.  Press the [+/-] buttons to select the other one.

If the internal format (P-N) is selected, program change and note information (note ON/OFF) commands will be transmitted.  
When the GM format (--N) is selected, only 'note on/off' commands will be transmitted.



*The above setting only affects the primary percussion channel (MIDI channel 10).*

## 7 Functions

### Switching the power ON

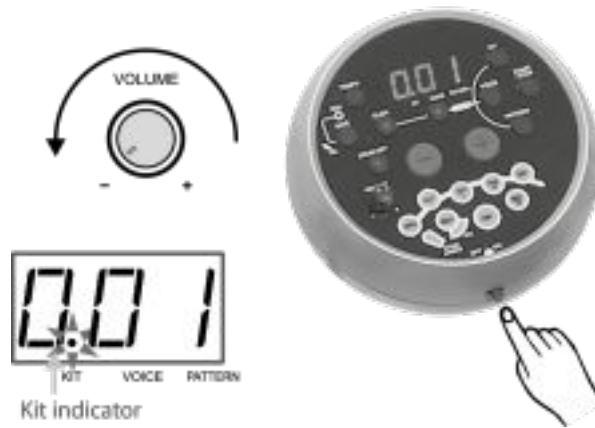

After all connections have been completed, rotate the volume knob to the left stop (= minimum volume level) before switching the power on.

Set the power switch to 'ON' position to switch the power on. The display then shows the 'Kit number' and the 'KIT' indicator lights up.

### Setting the overall volume



While hitting a pad, gradually rotate the volume knob until a comfortable volume level is reached.

### Selecting a drum kit

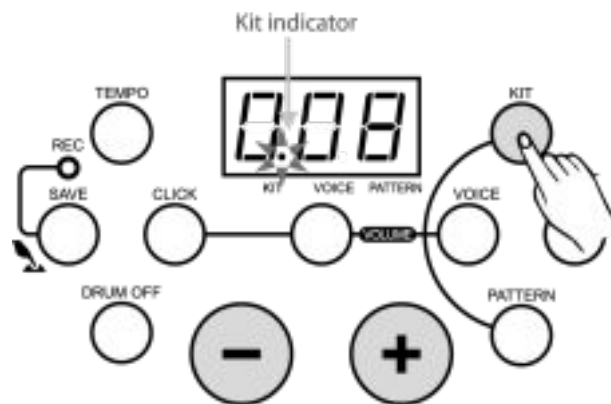



## Selecting a pad voice

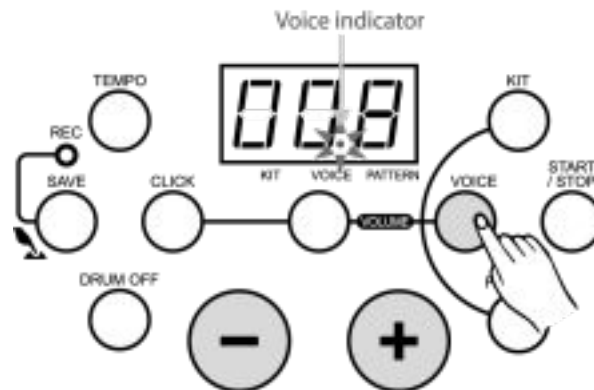

The drum module provides 108 built-in drum voices in total to choose from.

1. Press the **[VOICE]** button to enter pad voice selecting mode.  
⇒ The LED displays the current pad voice number and the 'VOICE' indicator lights up.
2. In pad voice selecting mode, press **[+/-]** buttons to choose the voice of the current pad or cymbal (1-108).

## Adjusting the pad volume

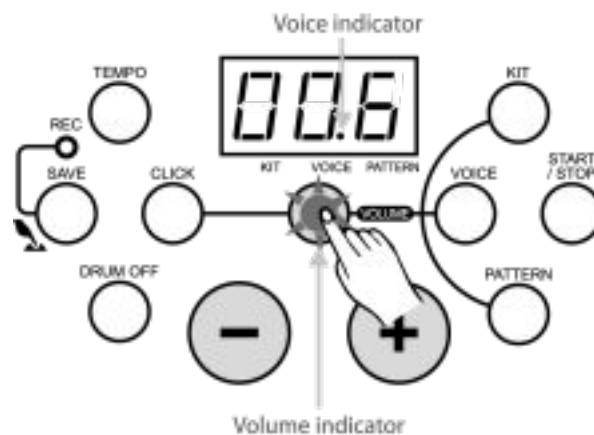

In voice selecting mode, press the **[VOLUME]** button to enter pad volume adjusting mode. Then the 'VOLUME' indicator lights up and the LED display shows the current pad volume value.

1. Press the **[+/-]** buttons to adjust its value (0-16).
2. Press the **[VOICE]** button again to enter voice selecting mode.

### Saving a kit

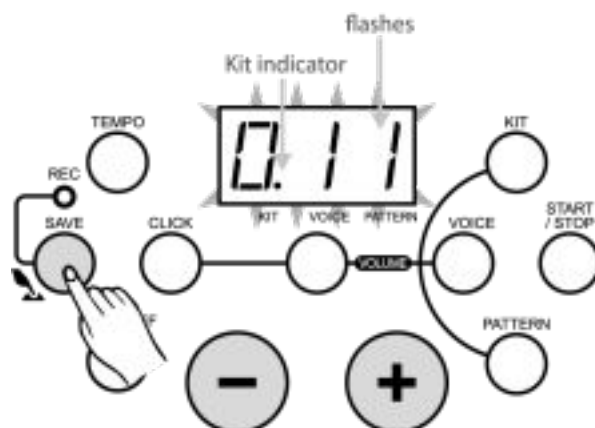

1. ➤ Press the [SAVE] button to enter KIT saving mode.
  - ⇒ The LED display shows the user KIT number to save, the 'KIT' indicator lights up and the user KIT number flashes.
2. ➤ Press the [+/-] buttons to choose the user KIT (11-15) to save.
  - ⇒ During choosing the kit, the user 'KIT' number will keep flashing.
3. ➤ Press the [SAVE] button again. All current settings including the pad voice and volume are now saved under the selected user 'Kit number'.



*When in recording mode, this function is not available to the user.*

### Selecting a pattern

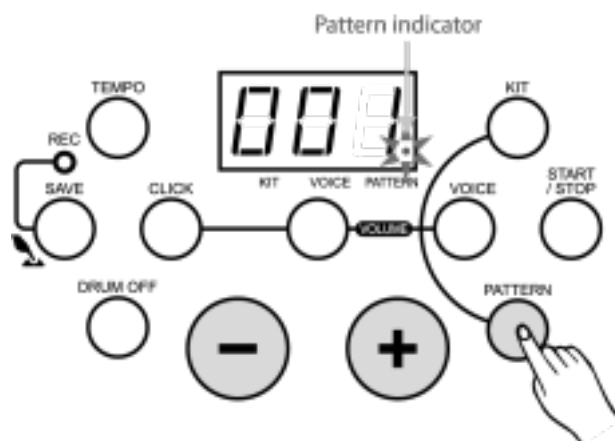

The unit offers 41 built-in patterns (40 preset patterns and one user pattern).

1. ➤ Press the **[PATTERN]** button to enter pattern choice mode.
  - ⇒ The LED display then shows the current pattern number and the pattern indicator lights up.
2. ➤ Press the **[+/-]** buttons to choose the current pattern number (1-41).

### Listening to a pattern

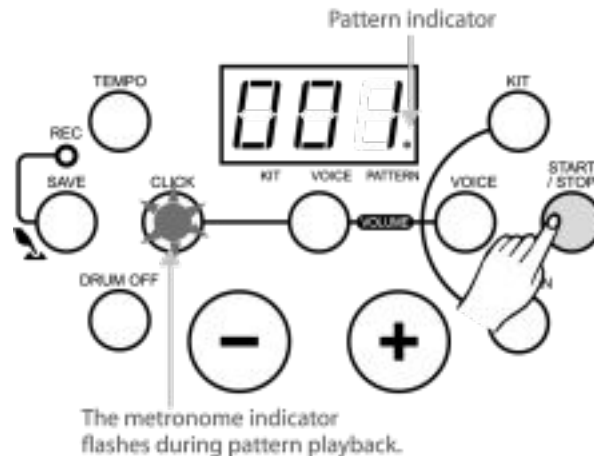

1. ➤ Press the **[START/STOP]** button to play the pattern.
  - ⇒ Meanwhile the 'PATTERN' indicator flashes and shows the beat of the playing pattern. Additionally the pad indicators light up and allow -together with the trigger sound- easy learning and practising. If another pattern is selected in current song playing, it will start to play at the next measure.
2. ➤ In pattern playing mode, press the **[START/STOP]** button to stop pattern playing.



*The pattern and the MIDI IN function use the same 16 midi channels. If you use the MIDI IN function during song playback, interference in the device may be caused. In this case you have to reset the unit by switching the drum module off and on again.*

## Adjusting the pattern volume

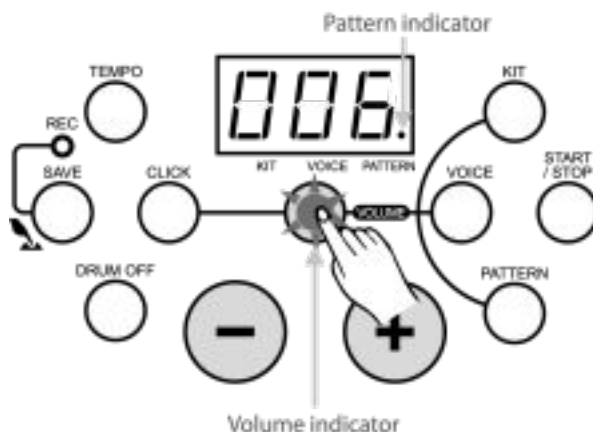

1. In pattern choice mode, press the **[VOLUME]** button to enter pattern volume adjusting mode.
  - ⇒ The LED display shows the accompaniment volume value for the current pattern. Please note that the percussion part volume can not be adjusted, it can only be muted on/off by using the **[DRUM OFF]** button. The volume indicator lights up.
2. Press the **[+/-]** buttons to adjust the pattern volume value (0-16).
3. Then press the **[PATTERN]** button again to return to pattern choice mode.
  - ⇒ Please note that in recording waiting mode, the pattern volume value is shown on the display but it can not be adjusted.



*Pattern volume only controls the accompaniment part volume of the pattern.*

## Hi-Hat control



- Open hi-hat: Strike the hi-hat without stepping on the pedal.
- Closed hi-hat: Strike the hi-hat with the pedal stepped.
- Closing the hi-hat: Completely step down the pedal.
- Splash: Play the hi-hat with the pedal fully stepped and then instantly release it.

## Factory reset

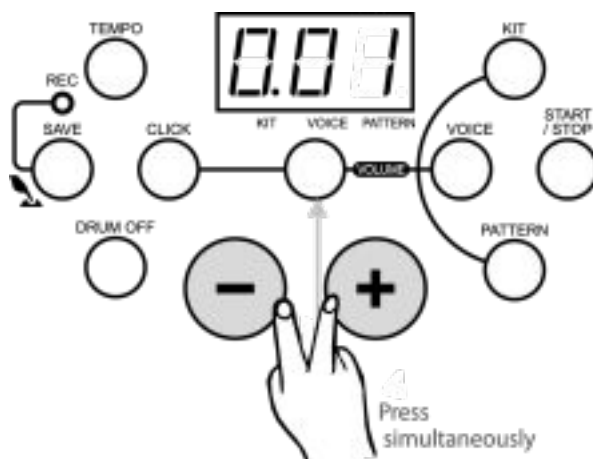

If you keep both [+ ] and [- ] buttons pressed at the same time when turning the drum module on, it will be reset to the factory default settings.

The following data will be replaced by the factory data:

- All users kits (include voice and volume settings)
- All recording data.

## 8 Recording

### Enter the recording waiting mode

1. Press and hold the [SAVE] button for about 2 seconds to enter user pattern recording waiting mode.

In recording waiting mode the following parameter can be adjusted:

- The 'pattern number' for the accompaniment
- The 'tempo'
- The 'kit number'
- The 'drum off' status
- 'metronome' on/off

⇒ The LED display indicates the current 'kit number' and the 'REC' indicator flashes.

2. Press the [PATTERN] button in recording waiting mode to display the pattern (---/001~040) for the automatic accompaniment for recording.
3. Select it using the [+/-] buttons.
4. Choose '---' if you'd like to record a solo drum part.

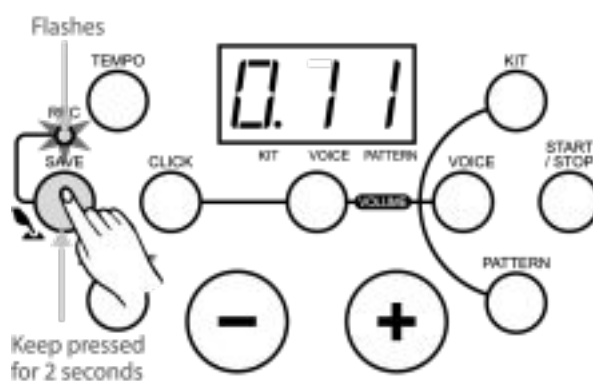

VOICE selecting function is not available in recording waiting mode.

### Enter recording mode

- No parameters can be adjusted during recording. Only [START/STOP] and [CLICK] buttons are available then.
- During recording the original data will be replaced with the newly recorded user pattern.
- The click sound will not be recorded.

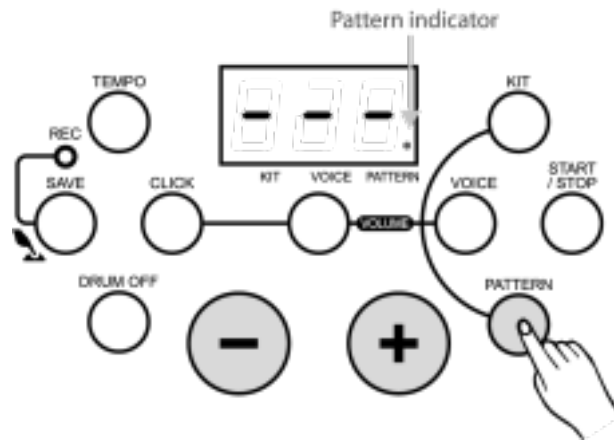

➔ Press the [START/STOP] button or hit the pads to enter recording mode.

⇒ The 'REC' indicator lights up and the LED display shows the recorded measures. First, an introductory beat will be counted down. The display then shows: '-4, -3, -2, -1'.

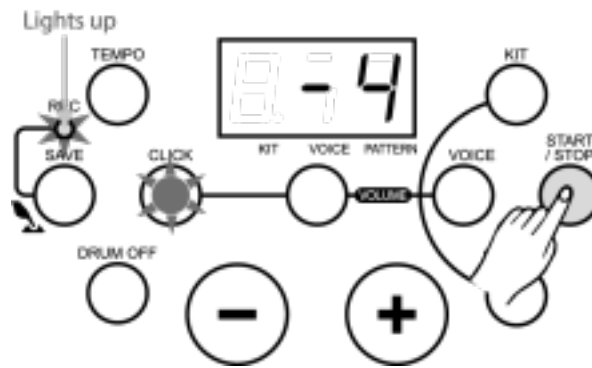

## Stop recording

When the recording memory is full, the recording automatically stops and the 'REC' indicator goes out.

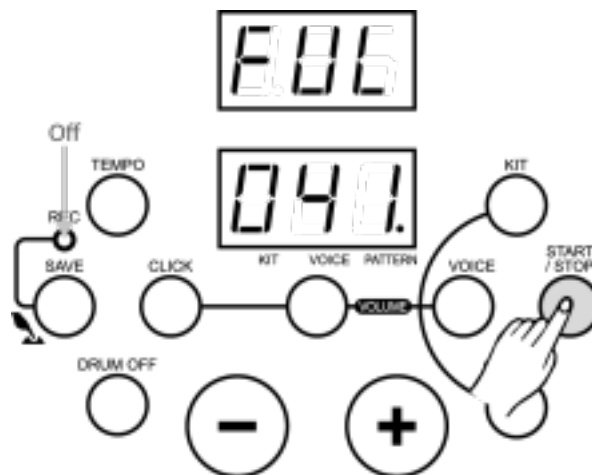

The LED display shows 'FUL'. Then press the [START/STOP] button to return to '41' display.

The recording capacity is about 5000 notes.

➔ Press the [START/STOP] button during recording to stop recording.

⇒ The 'REC' indicator goes out.

The device then returns to the pattern display '41'.

### Quick recording

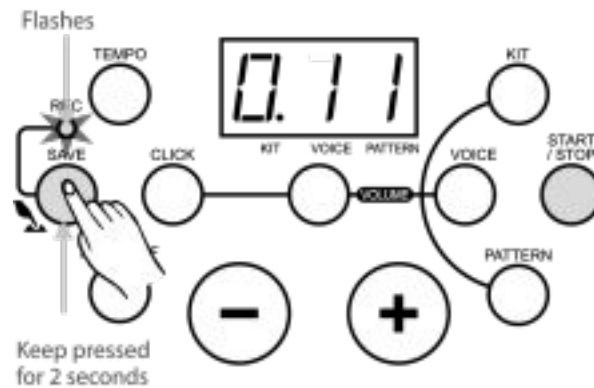

After choosing the desired drum kit and adjusting the parameters well (includes tempo, click etc.), you can start quick recording.

1. ➔ Keep the [SAVE] button pressed for about 2 seconds to enter recording waiting mode for recording a user pattern.
2. ➔ Hit the pads or press the [START/STOP] button to start recording.

## 9 Playback

### Playback a user pattern

1. ➤ Choose the pattern number '41'.
2. ➤ Press the [START/STOP] button to play the user pattern.
  - ⇒ If there is no recording data the LED display shows 'N-P'.

The LED display does not show any measures.

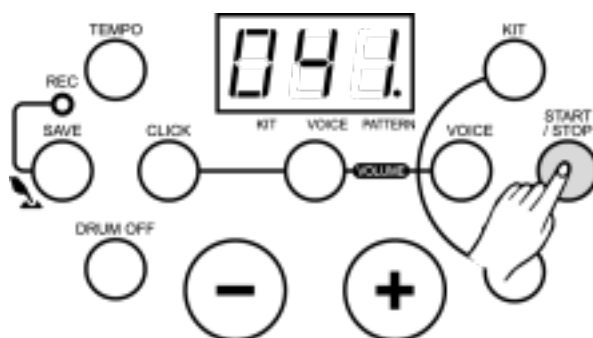

Please also note:

- The unit does not play the user pattern in cycle.
- If you press the [DRUM OFF] button only the accompaniment will be muted, but not the recorded part.
- Pattern volume and kit volume control the accompaniment and the recorded part.



*If you select another kit during the playback of a user pattern, the recorded kit data will also be changed to the currently selected kit.*

### DRUM OFF button

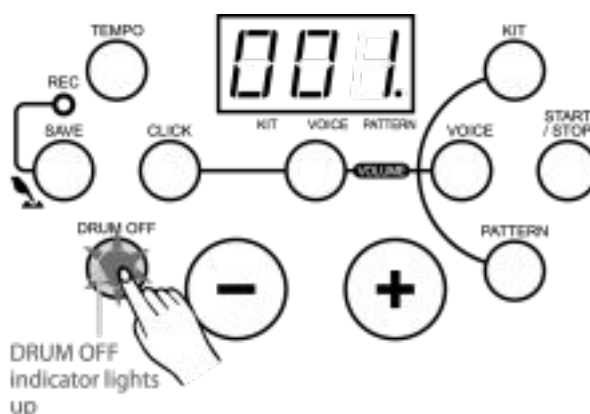

You can press the [DRUM OFF] button to mute or unmute the drum part.

If the DRUM OFF function is activated, the drum sound of the currently playing pattern will be muted and the 'DRUM OFF' indicator lights up.

This function is very convenient for user practise.

### Adjusting the pattern tempo

If you want to adjust the pattern tempo:

1. ➤ Press the [TEMPO] button.
  - ⇒ The LED display then temporarily shows the tempo value.
2. ➤ Press the [+/-] buttons to adjust the tempo for the metronome and pattern playback (30-280).

If you want to restore the preset value of the current pattern, press the [+] and [-] button simultaneously.

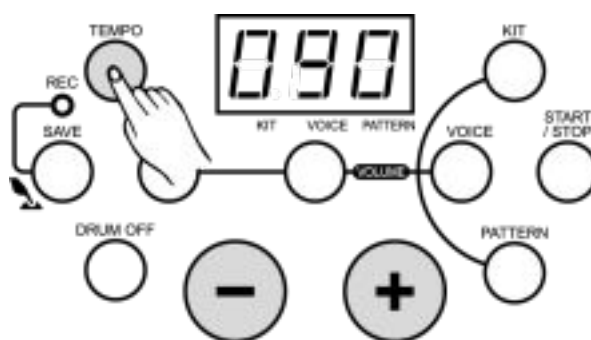

### Metronome function

If you want to use the metronome function:

1. ➤ Press the [CLICK] button to activate the metronome function.
  - ⇒ The LED display shows the current time signature and the 'CLICK' indicator flashes.
  - The following 9 time signatures can be chosen: (1/4, 2/4, 3/4, 4/4, 5/4, 6/4, 7/4, 3/8, 6/8).
2. ➤ Press the [+/-] buttons to change the time signature.
3. ➤ Press the [CLICK] button again to switch the metronome function off.

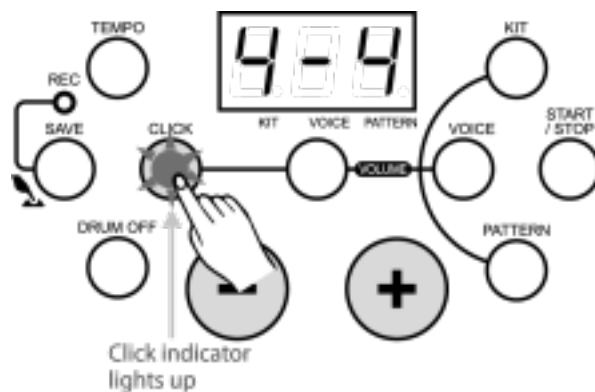

During pattern playback the 'CLICK' indicator flashes automatically according to the pattern beat, but the metronome sound will not automatically be activated.

## Selecting a click sound

If you want to select a click sound:

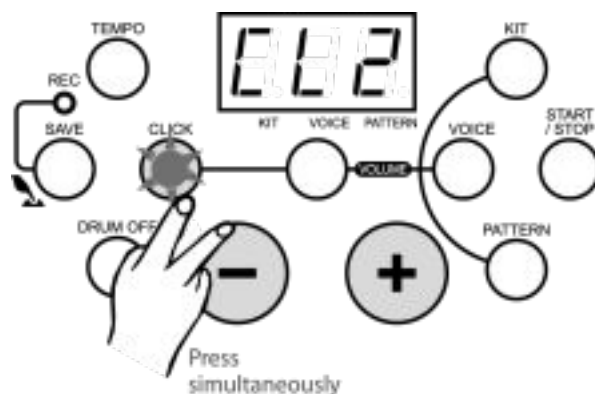

1. Keep the [CLICK] button pressed.
2. Then press the [+/-] buttons to select the desired metronome sound, i.e. the 'click'.
  - ⇒ The LED display temporarily shows the currently selected click sound.

4 click sounds are available: 'Metronome', 'Beep', 'Cowbell' and 'Voice'. The default preset sound when activating the metronome function is 'Metronome'.

## Adjusting the click volume

If you want to change the click volume:

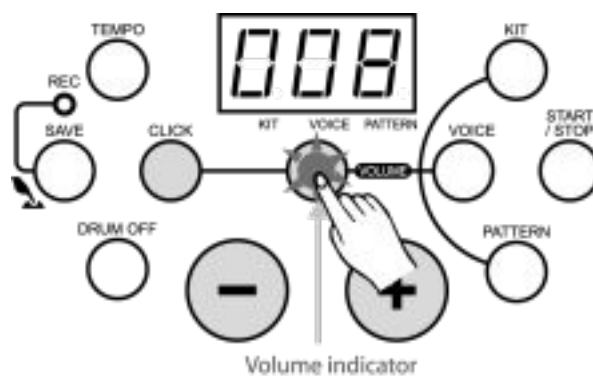

- 1.** In click time signature selecting mode press the *[VOLUME]* button to adjust the click volume.  
⇒ The volume indicator lights up and the LED display shows the current click volume value.
- 2.** Press the *[+/-]* buttons to select a value between 0 - 16.
- 3.** To return from click volume selection to time signature selection press the *[CLICK]* button.

## 10 Technical specifications

<b>Drum pads:</b>	3 tom pads
	2 cymbal pads
	1 snare pad (dual trigger)
	1 hi-hat
	1 hi-hat control pedal
	1 kick pad
<b>Number of voices:</b>	108
<b>Drum kits:</b>	10 preset kits
	5 user kits
<b>Patterns:</b>	40 preset songs and 1 user pattern
<b>Display:</b>	3-digit LED display
<b>Connections:</b>	PHONES
	USB
	OUTPUT
	MIX IN
	DC POWER
	Hi-hat control
	Hi-hat
	Crash
	Ride
	Snare
	Tom 1
	Tom 2
	Tom 3
	Kick
<b>Power supply:</b>	via AC mains adaptor (9 V =)

## 11 Voice list

No.	Name	No.	Name
<b>KICK</b>		<b>RIDE</b>	
001	Standard Kick 1	057	Classic Ride
002	Standard Kick 2	058	Rock Ride
003	Classic Kick 1	059	Brush Ride
004	Classic Kick 2	060	TR606 Ride
005	Rock Kick		
006	Camco Kick 1	<b>CRASH</b>	
007	Camco Kick 2	061	Classic Crash
008	Acoustic Kick 1	062	Rock Crash 1
009	Acoustic Kick 2	063	Rock Crash 2
010	Acoustic Kick 3	064	Brush Crash
011	Acoustic Kick 4	065	China Crash
012	TR606 Kick	066	TR606 Crash
<b>SNARE</b>		<b>HIHAT</b>	
013	Standard Snare	067	Classic Open Hi Hat
014	Standard Snare Rim	068	Rock Open Hi Hat
015	Funk Snare	069	TR606 Open Hi Hat
016	Funk Snare Rim		
017	Funk Stick	<b>Percussion</b>	
018	Classic Snare	070	Tabla 001
019	Classic Snare Rim	071	Tabla 002
020	Rock Snare	072	Tabla 003
021	Rock Snare Rim	073	Tabla 004
022	Brush Snare	074	Tabla 005
023	Brush Snare Rim	075	Tabla 006
024	Camco Snare	076	Bongo High
025	Camco Snare Rim	077	Bongo Low
026	TR606 Snare	078	Conga 1
		079	Conga 2

## Voice list

No.	Name	No.	Name
		080	Conga 3
<b>TOM</b>		081	Timbale High
027	Classic Tom 1	082	Timbale Low
028	Classic Tom 2	083	Agogo High
029	Classic Tom 3	084	Agogo Low
030	Classic Tom 4	085	Cowbell 1
031	Classic Tom 5	086	Cowbell 2
032	Classic Tom 6	087	Cowbell 3
033	Rock Tom 1	088	Cowbell 4
034	Rock Tom 2	089	Cowbell 5
035	Rock Tom 3	090	Cowbell 6
036	Rock Tom 4	091	Cowbell 7
037	Rock Tom 5	092	Cowbell 8
038	Rock Tom 6	093	Cowbell 9
039	Brush Tom 1	094	Cowbell 10
040	Brush Tom 2	095	Hi Hat 001
041	Brush Tom 3	096	Hi Hat 002
042	Brush Tom 4	097	Hi Hat 003
043	Brush Tom 5	098	Hi Hat 004
044	Brush Tom 6	099	Hi Hat 005
045	Camco Tom 1	100	Hi Hat 006
046	Camco Tom 2	101	Hi Hat 007
047	Camco Tom 3	102	Hi Hat 008
048	Camco Tom 4	103	Hi Hat 009
049	Camco Tom 5	104	Dj001
050	Camco Tom 6	105	Dj002
051	TR606 Tom 1	106	Dj003
052	TR606 Tom 2	107	Dj004
052	TR606 Tom 2	107	Dj004
053	TR606 Tom 3	108	Dj005
054	TR606 Tom 4		

No.	Name	No.	Name
055	TR606 Tom 5		
056	TR606 Tom 6		

**Preset kits and default user kits**

No.	Name	No.	Name
001	Standard	009	TR606
002	Rock	010	DJ
003	Pop	011	User kit1 (Standard)
004	Funk	012	User kit2 (Rock)
005	Brush	013	User kit3 (Pop)
006	Jazz	014	User kit4 (Funk)
007	Table	015	User kit5 (Brush)
008	Latin		



*Numbers 001~010 stand for preset kits, numbers 011~015 stand for user kits.*

## 12 Pattern list

Nr.	Pattern	Nr.	Pattern
001	Fusion1	022	Fusion2
002	Latin Jazz1	023	Jazz1
003	Funk1	024	Guitar Bossa
004	Latin Pop1	025	Break Beat
005	60's Rock	026	World1
006	Big Band1	027	Funk3
007	Drum N'Bass	028	Latin Jazz3
008	Ballad	029	Latin Pop2
009	Swing	030	Reggae1
010	Pop1	031	World2
011	Funk2	032	Latin
012	Latin Jazz2	033	Bossa
013	Pop Funk1	034	Samba2
014	Latin Rock1	035	3/4Pop
015	Big Band2	036	Pop2
016	Pop Ballad	037	Jazz2
017	Pop Funk2	038	Reggae2
018	3/4Jazz	039	Reggae3
019	Pop Bossa	040	Latin Rock2
020	Samba1	041	User pattern
021	6/8Ballad		

## 13 Percussion settings

Prg.-Nr.	Standard (PC0)	Rock (PC1)	Pop (PC2)	Funk (PC3)	Brush (PC4)	Jazz (PC5)	606 (PC6)	DJ (PC7)
27	High Q	-	-	-	-	-	-	-
28	Slap	-	-	-	-	-	-	-
29	Scratch Push	-	-	-	-	-	-	-
30	Scratch Pull	-	-	-	-	-	-	-
31	Sticks	-	-	-	-	-	-	-
32	Square Click	-	-	-	-	-	-	-
33	Metronome Click	-	-	-	-	-	-	-
34	Metronome Bell	-	-	-	-	-	-	-
35	STD Kick 2	-	-	-	-	-	-	-
36	STD Kick 2	Rock Kick	Pop Kick	Funk Kick	Brush Kick	Jazz Kick	TR606 Kick	-
37	Side Stick	-	-	-	-	-	-	-
38	STD Snare	Rock Snare	Pop Snare Drum	Funk Snare	Brush Snare	Jazz Snare	TR606 Snare	-
39	Hand Clap	-	-	-	-	-	-	-
40	STD Snare Rim	Rock Snare Rim	Pop Snare Rim	Funk Snare Rim	Brush Snare Rim	Jazz Snare Rim	TR606 Snare Rim	-
41	STD Low Tom 2	Rock Low Tom 2	Pop Low Tom 2	Funk Low Tom 2	Brush Low Tom 2	Jazz Low Tom 2	TR606 Low Tom 2	-
42	Closed Hi-Hat	-	-	-	-	-	TR606 Closed Hi-Hat	-
43	STD Low Tom 1	Rock Low Tom 1	Pop Low Tom 1	Funk Low Tom 1	Brush Low Tom 1	Jazz Low Tom 1	TR606 Low Tom 1	-
44	Pedal Hi-Hat	-	-	-	-	-	TR606 Pedal Hi-Hat	-
45	STD Mid Tom 2	Rock Mid Tom 2	Pop Mid Tom 2	Funk Mid Tom 2	Brush Mid Tom 2	Jazz Mid Tom 2	TR606 Mid Tom 2	Dj Mix 5
46	Open Hi-Hat	-	-	-	-	-	TR606 Open Hi-Hat	-
47	STD Mid Tom 1	Rock Mid Tom 1	Pop Mid Tom 1	Funk Mid Tom 1	Brush Mid Tom 1	Jazz Mid Tom 1	TR606 Mid Tom 1	Dj Mix 4
48	STD Hi Tom 2	Rock Hi Tom 2	Pop Hi Tom 2	Funk Hi Tom 2	Brush Hi Tom 2	Jazz Hi Tom 2	TR606 Hi Tom 2	Dj Mix 3

## Percussion settings

Prg.-Nr.	Standard (PC0)	Rock (PC1)	Pop (PC2)	Funk (PC3)	Brush (PC4)	Jazz (PC5)	606 (PC6)	DJ (PC7)
49	Crash Cymbal 1	-	-	-	-	-	TR606 Crash Cymbal 1	Dj Mix 2
50	STD Hi Tom 1	Rock Hi Tom 1	Pop Hi Tom 1	Funk Hi Tom 1	Brush Hi Tom 1	Jazz Hi Tom 1	TR606 Hi Tom 1	-
51	Standard Ride	Rock Ride	-	-	Brush Ride	-	-	Dj Mix 1
52	Chinese Cymbal	-	-	-	-	-	-	-
53	Ride Bell	-	-	-	-	-	-	-
54	Tambourine	-	-	-	-	-	-	-
55	Splash Cymbal	-	-	-	-	-	-	-
56	Cowbell	-	-	-	-	-	-	-
57	Crash Cymbal 2	-	-	-	-	-	-	-
58	Vibraslap	-	-	-	-	-	-	-
59	Ride Cymbal 2	-	-	-	-	-	-	-
60	Hi Bongo	-	-	-	-	-	-	-
61	Low Bongo	-	-	-	-	-	-	-
62	Mute Hi Conga	-	-	-	-	-	-	-
63	Open Hi Conga	-	-	-	-	-	-	-
64	Low Conga	-	-	-	-	-	-	-
65	High Timbale	-	-	-	-	-	-	-
66	Low Timbale	-	-	-	-	-	-	-
67	High Agogo	-	-	-	-	-	-	-
68	Low Agogo	-	-	-	-	-	-	-
69	Cabasa	-	-	-	-	-	-	-
70	Maracas	-	-	-	-	-	-	-
71	Short Whistle	-	-	-	-	-	-	-
72	Long Whistle	-	-	-	-	-	-	-
73	Short Guiro	-	-	-	-	-	-	-
74	Long Guiro	-	-	-	-	-	-	-

Prg.-Nr.	Standard (PC0)	Rock (PC1)	Pop (PC2)	Funk (PC3)	Brush (PC4)	Jazz (PC5)	606 (PC6)	DJ (PC7)
75	Claves	-	-	-	-	-	-	-
76	Hi Wood Block	-	-	-	-	-	-	-
77	Low Wood Block	-	-	-	-	-	-	-
78	Mute Cuica	-	-	-	-	-	-	-
79	Open Cuica	-	-	-	-	-	-	-
80	Mute Triangle	-	-	-	-	-	-	-
81	Open Triangle	-	-	-	-	-	-	-
82	Shaker	-	-	-	-	-	-	-
83	Jingle Bell	-	-	-	-	-	-	-
84	Belltree	-	-	-	-	-	-	-
85	Castanets	-	-	-	-	-	-	-
86	Mute Surdo	-	-	-	-	-	-	-
87	Open Surdo	-	-	-	-	-	-	-

Boxes marked with '-' have the same assignment as listed in column **Standard (PC0)**.

## 14 MIDI implementation chart

Function		Transmitted	Received	Remarks
Basic Channel	Default	ch 10	1-16	
	Changed	No	No	
Mode	Default	No	No	
	Messages	Yes	No	
	Altered	*****	*****	
Note Number	True voice	0~127	0~127	
		*****	0~127	
Velocity Note	Note ON	Yes (99H, V: 0~127)	Yes	
	Note OFF	Yes (99H, V: 0)	Yes	
After Touch	Keys	No	No	
	Channels	No	No	
Pitch Bend		No	Yes	
Control Change	0	No	Yes	Bank Select
	1	No	Yes	Modulation
	5	No	Yes	Portamento Time
	6	No	Yes	Data Entry
	7	No	Yes	Volume
	10	No	Yes	Pan
	11	No	Yes	Expression
	64	No	Yes	Sustain Pedal
	65	No	Yes	Portamento ON/OFF
	66	No	Yes	Sostenuto Pedal
	67	No	Yes	Soft Pedal
	80	No	Yes	Reverb Program <sup>1)</sup>
	81	No	Yes	Chorus Program <sup>2)</sup>
	91	No	Yes	Reverb Level
	93	No	Yes	Chorus Level
	120	No	Yes	All Sound Off
	121	No	Yes	Reset All Controllers
123	No	Yes	All Notes Off	

Function		Transmitted	Received	Remarks
Program Change		Yes	Yes	
System Exclusive		No	Yes	
System Common	Song Position	No	No	
	Song Select	No	No	
	Tune	No	No	
System Clock		No	No	
Real Time Commands		No	No	
Aux Messages	Local ON/OFF*	No	No	
	ALL Notes OFF	No	Yes	
	Active Sensing	Yes	No	
	System Reset	No	No	

Table note 1

- Reverb program vv = 00H to 07H (default 04H)
  - 00H : Room1
  - 01H : Room2
  - 02H : Room3
  - 03H : Hall1
  - 04H : Hall2
  - 05H : Plate
  - 06H : Delay
  - 07H : Pan delay

Table note 2

- Chorus program vv = 00H to 07H (default 02H)
  - 00H : Chorus1
  - 01H : Chorus2
  - 02H : Chorus3
  - 03H : Chorus4
  - 04H : Feedback
  - 05H : Flanger
  - 06H : Short delay
  - 07H : FB delay

Table note 3

- Just respond 3 type of RPN 000~002.

# 15 Cleaning

### Components

Clean the accessible parts of the device regularly. The frequency of cleaning depends on the operating environment: moist, smoky or particularly dirty environments may cause a higher accumulation of dirt on the components of the device.

- Use a dry soft cloth for cleaning.
- Remove stubborn stains with a slightly damp cloth.
- Never use cleaners containing alcohol or thinner.
- Never put any vinyl items on the device, as vinyl can stick to the surface or lead to its discolouration.

## 16 Protecting the environment

### Disposal of the packaging material



For the transport and protective packaging, environmentally friendly materials have been chosen that can be supplied to normal recycling.

Ensure that plastic bags, packaging, etc. are properly disposed of.

Do not just dispose these materials with your normal household waste, but make sure that they are fed to a recovery. Please follow the notes and markings on the packaging.

### Disposal of your old device



This device is subject to the European directive 2002/96/EC.

Do not dispose the device with your normal household waste.

Dispose this device through an approved waste disposal firm or through your local waste facility. When discarding the device, comply with the rules and regulations that apply in your country. If in doubt, consult your local waste disposal facility.





