

Appendix C: Technical Information

Specifications

Main Mix Noise

(20 Hz–20 kHz bandwidth, 1/4" main out, channels 1–2 gain @ unity, channel EQs flat, stereo-pan button in.)

Main mix knob down, channel level knobs down: –103 dBu

Main mix knob unity, channel level knobs down: –98 dBu

(102 dB Signal to Noise Ratio, ref +4 dBu)

Main mix knob @ unity, and channel level knobs @ unity: –92 dBu

Total Harmonic Distortion (THD)

(1 kHz @ 35 dB gain)

20 Hz–80 kHz bandwidth <0.005%

20 Hz–20 kHz bandwidth <0.003%

Attenuation (Crosstalk)

(1 kHz relative to 0 dBu, 20 Hz–20 kHz bandwidth, line in, 1/4" main out, gain @ unity.)

Main mix knob down: –70 dBu

Channel level knob down: –94 dBu

Frequency Response

(Mic input to any output.)

20 Hz to 50 kHz: +0 dB/–1 dB

20 Hz to 90 kHz: +0 dB/–3 dB

Equivalent Input Noise (EIN)

(Mic in to main out, max gain.)

150 ohm termination: –129.5 dBu

20 Hz–20 kHz

Common Mode Rejection Ratio (CMRR)

1 kHz: better than –70 dB

Maximum Levels

Mic in: +21 dBu

Tape in: +24 dBu

All other inputs: +22 dBu

All outputs: +22 dBu

Impedances

Mic in: 3.4 kilohms

All other inputs: 10 kilohms or greater

Tape out: 1.0 kilohms

Phones output: 60 ohms

All other outputs: 120 ohms

EQ

High Shelving ±15 dB @ 12 kHz

Low Shelving ±15 dB @ 80 Hz

Power Consumption

8 watts

(H x W x D)

7.3" x 5.8" x 1.6"

(185.5 mm x 146.9 mm x 40.7 mm)

Weight

With power supply 3.0 lb (1.36 kg)

Without power supply 2.5 lb (1.1 kg)

LOUD Technologies Inc. is always boldly striving to improve our products by incorporating new and improved materials, components, and manufacturing methods. Therefore, we reserve the right to change these specifications at any time without notice.

"Mackie," and the "Running Man" are registered trademarks of LOUD Technologies Inc. All other brand names mentioned are trademarks or registered trademarks of their respective holders, and are hereby acknowledged.

The technical writer responsible for this owner's manual lives in an odd kind of dreamworld on Thursday afternoons. Therefore it is possible that all the instructions given here might only be true on a small blue-purple planet in the outer spiral arm of the Great Andromeda Galaxy. Please check our website for any possible updates to this manual.

©2007-2008 LOUD Technologies Inc.
All Rights Reserved.

Block Diagram

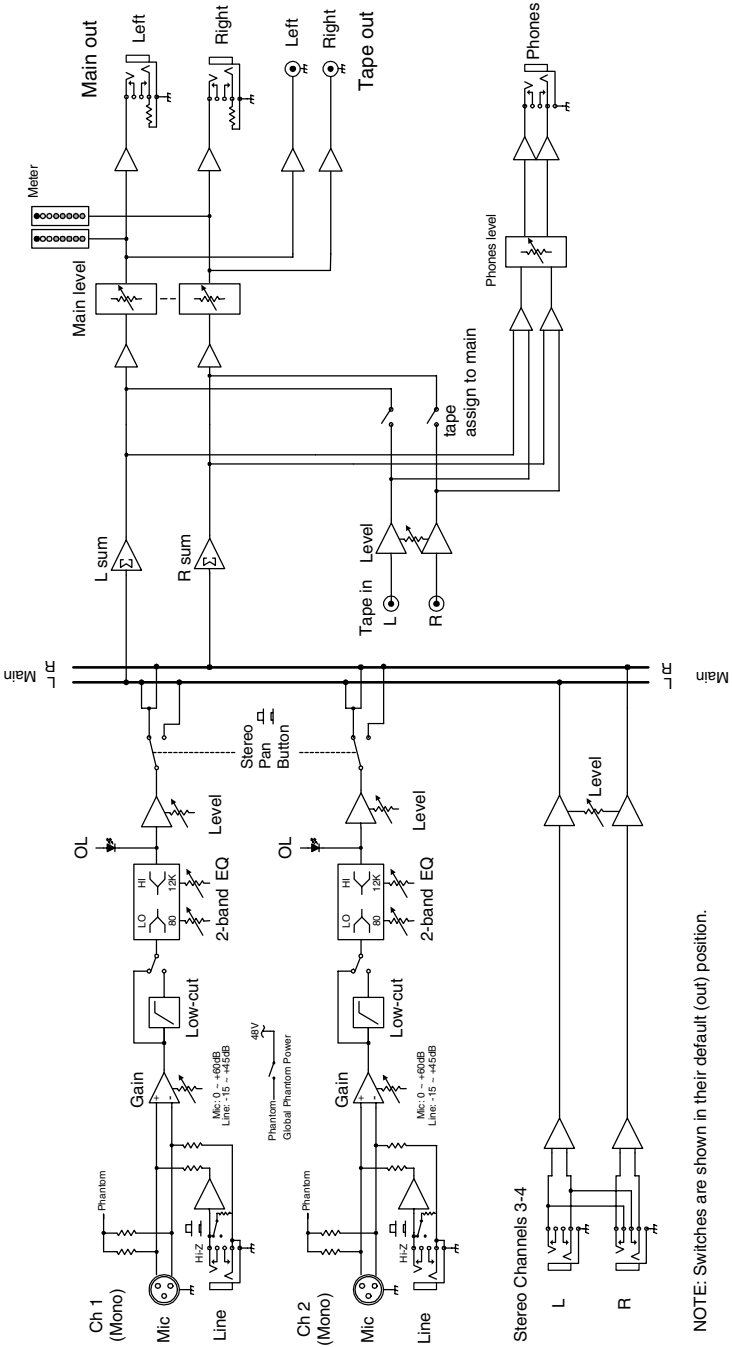

NOTE: Switches are shown in their default (out) position.

Dimensions

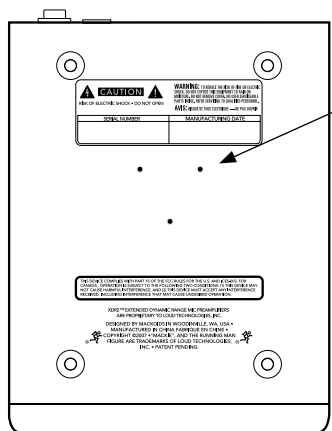
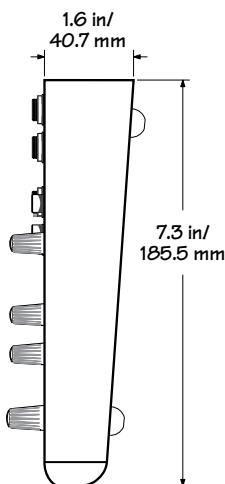
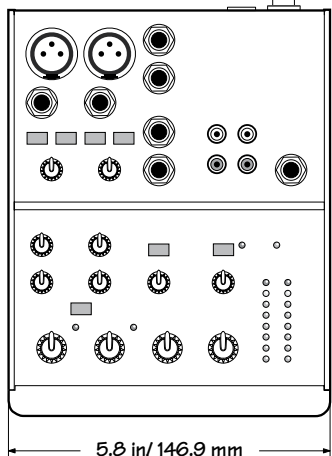
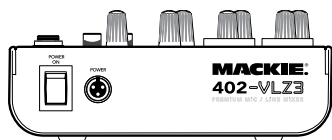

Microphone Stand

The bottom panel of the 402-VLZ3 has three non-threaded holes that allow it to be fitted with an optional microphone stand adapter. This allows you to support the mixer on a standard mic stand and adjust its height and level to whatever suits your strangely-complex set of preferences.

1. Order the Atlas AD-11B mic stand adapter available from many a fine music store. (It is made and distributed by Atlas Sound.)
2. Use three self-tapping machine screws 6-32 x 1/4" long to secure the adapter to the bottom of the 402-VLZ3.



Do not use screws that are longer than 1/4" as these could damage the circuit boards. Do not use any shorter screws, or the adapter will not be securely fixed to the mixer. Using chewing gum to secure the adapter is out of the question.

3. Do not order the AD-11, as this is a pack of 100. If you do, please send for the informative booklet entitled "99 things to do with a mic stand adapter."