



Models WH30TQG and WH30XLR User Guide

MODEL WH30 CONDENSER HEADSET MICROPHONE



WH30XLR
ONLY

INTRODUCTION

The Shure Model WH30 is a light yet rugged headset microphone. Designed for vocalists and instrument-playing vocalists, the WH30 utilizes a high quality electret-condenser cartridge suitable for all applications where mobility, comfort, low microphone-visibility, and high sound quality are required. Because of its cardioid (unidirectional) pickup pattern, the WH30 provides isolation from extraneous sound sources and high gain-before-feedback.

The wireframe and gooseneck adjust to any head size and shape. An integrated elastic CROAKIES[®] headband comfortably pads and secures the headset. The WH30 is supplied with two snap-on windscreens, clothing clip, storage bag and cable-management device.

FEATURES

- *Smooth, natural frequency response comparable to professional condenser hand-held microphones*
- *Lightweight wireframe and headband adjust for a secure, comfortable fit*
- *Extra-strong, small-diameter microphone cable resists breakage*
- *Moisture-proof cartridge housing*
- *Sturdy gooseneck-boom holds mic securely in place*
- *Isolation shock mount for reduced handling noise*
- *Matte black finish for low visibility*
- *High input clipping level helps avoid overload distortion*
- *Low self-noise and high sound pressure level capability*
- *Reliable at temperature and humidity extremes*

MODEL VARIATIONS

- **WH30TQG:** For wireless use, the WH30TQG has a 1.5m (5 ft.) high-flex cable and a mini TA4F connector for direct connection to Shure body pack transmitters. (Note: for information about use with Shure W10BT or other transmitters without a mini TA4F connector, contact Shure Customer Service).
- **WH30XLR:** For wired applications, the WH30XLR is supplied with a 1.5m (5 ft.) hi-flex cable and high quality mic preamplifier (RPM420) with a three pin XLR connector. The RPM420 preamplifier requires phantom power from any 11 – 52 V source.

MICROPHONE PARTS

The WH30 consists of the following parts (see Figure 1).

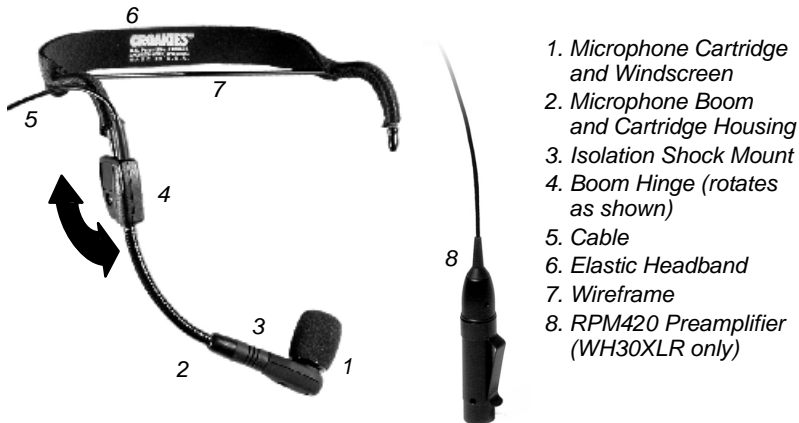

1. *Microphone Cartridge and Windscreen*
2. *Microphone Boom and Cartridge Housing*
3. *Isolation Shock Mount*
4. *Boom Hinge (rotates as shown)*
5. *Cable*
6. *Elastic Headband*
7. *Wireframe*
8. *RPM420 Preamplifier (WH30XLR only)*

FIGURE 1. WH30 HEADSET MICROPHONE PARTS

COLLAPSIBLE MICROPHONE BOOM

The WH30 headset features a collapsible boom for shipment and storage.

Before wearing the headset, unfold the boom by rotating it away from the wireframe until it snaps into place. Refold for storage or transportation.

WEARING THE HEADSET

Place the headset wireframe around your head so that the elastic headband lay horizontally across the back of your head and the ends of the wireframe fit over your ears. You may position the elastic headband either above or below the wireframe for the greatest comfort and stability. The blue “SHURE” logo should face outward (see Figure 2).



FIGURE 2. WEARING THE HEADSET



FIGURE 3. POSITIONING THE MICROPHONE

ADJUSTING THE HEADSET

- If the headset feels loose or uncomfortable, carefully bend the sides of the wireframe to make it tighter or looser (see Figure 4A). The angle of the wireframe earpieces may also need adjustment (see Figure 4B).
- Adjust the tension of the elastic headband across the back of the head by sliding it up or down the ends of the wireframe (see Figure 5).

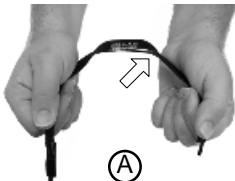

(A)



(B)

FIGURE 4. ADJUSTING THE WIREFRAME

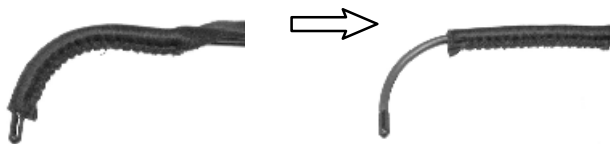

FIGURE 5. ELASTIC HEADBAND ADJUSTMENT

USING THE CABLE RETAINER AND CLOTHING CLIP

Use the cable retainer on the wire frame of the headset to position the microphone cable as desired. The supplied spring-loaded clothing clip secures the microphone cable to the user's clothing to help avoid entanglement.

POSITIONING THE MICROPHONE

For maximum gain-before-feedback, position the microphone and boom so that the microphone is within 13 mm (1/2 inch) of the *right corner* of your mouth (see Figure 3). This will also help minimize breath noise or “popping”.

CONNECTING THE WH30 TO A SOUND SYSTEM

WIRELESS APPLICATIONS (WH30TQG)

1. Connect the mini TA4F connector from the WH30 to a wireless microphone transmitter such as the Shure T1 bodypack transmitter.
2. See the user guide for your wireless transmitter and receiver system for adjusting gain and other parameters.

WIRED APPLICATIONS (WH30XLR)

Connect the output of the RPM420 preamplifier to an input channel of a mixing or recording console. Most consoles will provide phantom power to the RMP420 preamplifier. If phantom power is unavailable, use a separate phantom power supply such as the Shure PS1A.

WASHING THE ELASTIC HEADBAND

When necessary, remove and wash the elastic headband according to these steps.

1. Remove the microphone cable retainer from the wireframe.
2. Slide the elastic headband off the wireframe.

3. Wash the headband in mild, soapy water and rinse it in clean water.
4. Allow the headband to air-dry thoroughly.
5. Slide the headband around the wireframe to its original position. Reattach the cable with the plastic retainer.

WASHING THE FOAM WINDSCREEN

The foam windscreen protects the WH30's microphone-element from dirt and moisture. When necessary, it can be removed and cleaned in a mild soapy water solution. *Important: Never clean the windscreen with any liquid solution without first removing the windscreen from the microphone boom.*

1. Hold the windscreen loosely by the plastic retaining ring at its base.
2. Gently pull the windscreen away from microphone. The plastic retaining ring will expand to allow the windscreen to slip off the microphone. If necessary, you can expand the ring manually with a small screwdriver as you pull the windscreen.
3. Immerse the windscreen in mild soapy water and gently squeeze it several times.
4. Rinse the windscreen in clean water and dry it with a clean cloth or paper towel. Allow it to air-dry thoroughly.
5. When the windscreen is dry, slide it over the WH30 microphone until the retaining ring snaps into place.

CERTIFICATION

The WH30XLR conforms to European EMC Directive 89/336/EEC, and is eligible to bear the CE marking. Meets applicable tests and performance criteria in European standard EN 55103 (1996) parts 1 and 2, for residential (E1) and light industrial (E2) environments. The WH30TQG conforms to European EMC Directive 89/33/EEC, and is eligible to bear the CE marking. Meets EMC requirements as an ancillary device per EN 300 445 (1996)

REPLACEMENT PARTS

Cable Connector (for WH30TQG only)	WA330
Connector Belt Clip (for WH30XLR only)	RK200BC
Elastic Headband	80A505B
Wireframe, Headband, Boom Hinge, Boom, Shock Mount, Cartridge Housing and Cable	RPM520
Preamplifier Assembly	RPM420
Black Windscreens (2) and Clothing Clip	90WP1371

SPECIFICATIONS	WH30TQG	WH30XLR
Type	Condenser, electret bias	Condenser, electret bias with integrated preamplifier
Frequency Response	40 to 20,000 Hz (See Figure 6)	
Polar Pattern	Unidirectional (cardioid) (see Figure 7)	
Output Impedance (at 1kHz)	2400 Ω	Rated 150 Ω (actual) (Tolerates loads as low as 150 Ω with reduced clipping level)
Output Level (at 1 kHz; 0 dB = 1 V/Pascal)	-55.5 dB (1.7 mV)	-54.5 dB (1.9 mV)
Signal to noise ratio (ref. A-weighted noise)	63.0 dB at 94 dB SPL (IEC 651)	
Output Clipping Level (at 1000 Hz)	-22 dBV (0.08 V)	2.5K Ω Load: -8 dBV (0.4V) 1 K Ω Load: -8 dBV (0.4V)
Maximum SPL	130 dB	2.5K Ω Load: 142 dB 1 K Ω Load: 142 dB
Dynamic Range (max. SPL to A-weighted noise level)	99 dB	111 dB
Output Noise (equivalent SPL)	31 dB (typical, A-weighted)	
Recommended Operating Voltage	5 VDC (pin 2 to pins 3 and 4)	11–52 VDC Phantom power
Polarity	Positive sound pressure on diaphragm produces positive voltage on pins 3 and 4 relative to pin 1 (ground) on the mini TA4F connector.	Positive sound pressure on the diaphragm produces positive voltage on pin 2 relative to pin 3 of preamplifier output connector.
Environmental Conditions	Operating Temperature . . . -7° to 49° C (20° to 120° F) Storage Temperature . . . -29° to 74° C (-20° to 165° F) Humidity: 0 to 95 % (operating or storage)	
Cable	3.05 m (10 ft), two-conductor, shielded	
Cable Connector	mini TA4F	XLR
Net Weight	Headset: 65 g (2.3 oz)	Headset and cord: 60 g (2.1 oz) Preamplifier: 99 g (3.5 oz)

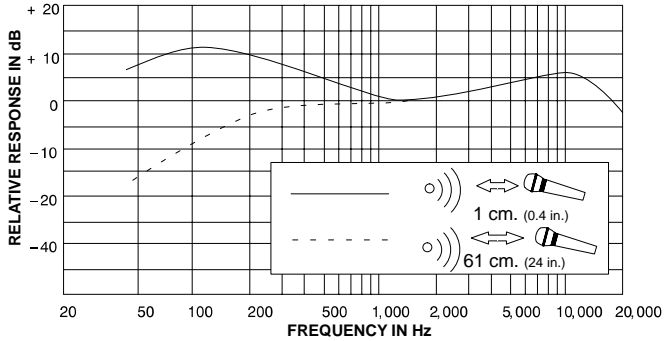

FIGURE 6. WH30: TYPICAL FREQUENCY RESPONSE

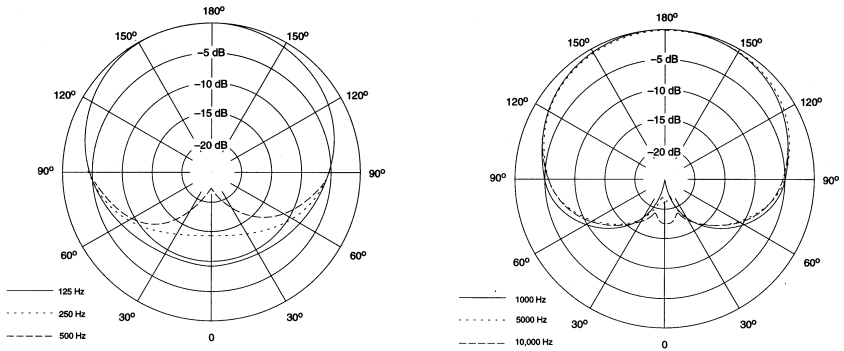

FIGURE 7. WH30: TYPICAL POLAR PATTERNS

WIRING DIAGRAMS

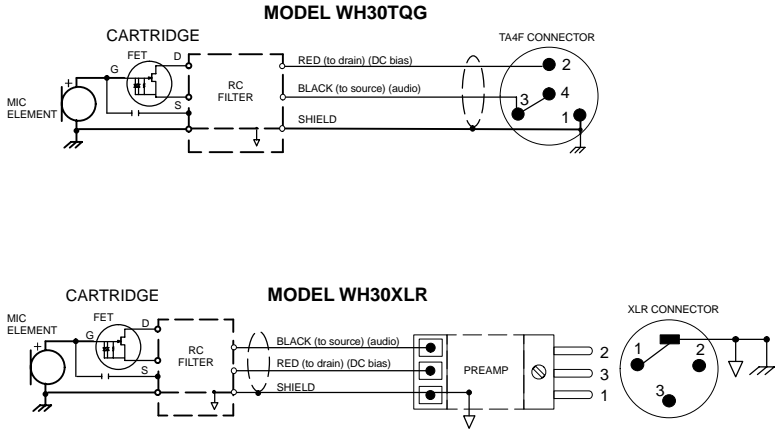

FIGURE 8. WIRING DIAGRAMS

Trademark Notices: The stylized Shure logo and the word “Shure” are registered trademarks of Shure Incorporated in the United States. “Teflon” is a registered trademark of E.I. duPont de Nemours and Company in the United States. “Croakies” is a registered trademark of Life-Link International, Inc.



SHURE Incorporated Web Address: <http://www.shure.com>
222 Hartrey Avenue, Evanston, IL 60202-3696, U.S.A.
Phone: 847-866-2200 Fax: 847-866-2279
In Europe, Phone: 49-7131-72140 Fax: 49-7131-721414
In Asia, Phone: 852-2893-4290 Fax: 852-2893-4055
Elsewhere, Phone: 847-866-2200 Fax: 847-866-2585